

# ***Akiyama-Probe (A-Probe)*** ***technical guide***

***This technical guide presents: how to make a proper setup for operation of Akiyama-Probe.***

***Akiyama-Probe is a patented technology.***

## Introduction

---

To benefit from the advantages of Akiyama-Probe, a proper operation setup is required. In order to save some time and effort, a commercial instrument should be the first choice. One can obtain the best performance in a shorted time. An alternative to the commercially available/offered solution is building one's own setup. This technical guide is intended for those who prefer the latter. Many examples and suggestions in this guide will help to overcome common problems at the first step.

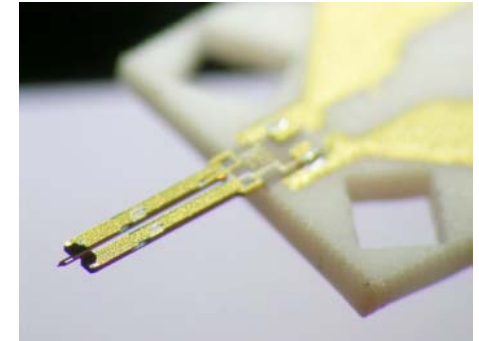

The following points have to be considered to build an own setup:

- How to physically fix Akiyama-Probe with two electrical connections
- Electrical configuration (self-oscillation, frequency measurement)
  - pre-amplifier
  - electronics for self-oscillation
  - phase locked loop (PLL)

Note that some contents in this guide may not apply to your specific setup. Please use this guide as a general reference only.

## Operation setup

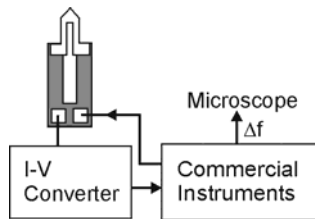

### Commercial instruments:

Many instruments and equipments (AFM, PLL, amplifiers and etc.) are commercially available for Akiyama-Probe operation. They are very reliable and highly recommended to use.

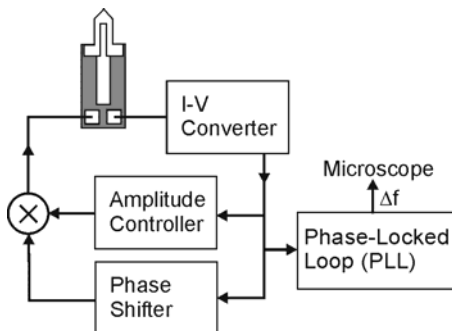

### Build your own setup with analog electronics:

A self-oscillation circuit can be built with some OP-amps. In a simple case, the PLL can be outside of the self-oscillation loop and works in a passive mode. If a single chip PLL (e.g., 4046) is used, a complete setup can be built with a low budget. If a higher resolution is required in this configuration, the simple PLL can be replaced with a more accurate commercial PLL without any major modification of the setup.

M. Ferrara, *Nanotechnology* 14, 427–432 (2003)

J. Jersch, *et al.*, *Rev. Sci. Instrum.* 77, 083701 (2006)

H.-P. Rust, *et al.*, *Rev. Sci. Instrum.* 77, 043710 (2006)

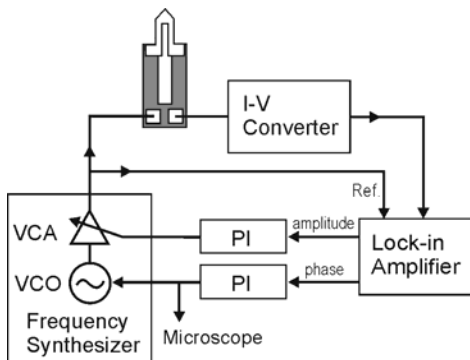

### Laboratory standard instruments + minimum analog electronics:

One can make a very high resolution “self-oscillation + PLL” setup with two standard laboratory instruments (lock-in amplifier and frequency synthesizer) and a very simple analog circuit. The analog circuit with a few OP-amps forms a proportional-integral gain controller.

J. Rychen, *et al.*, *Rev. Sci. Instrum.* 70, 2765 (1999)

# Akiyama-Probe specifications

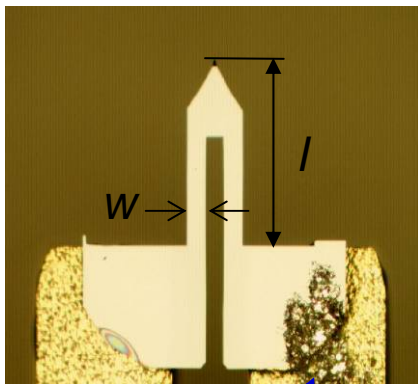
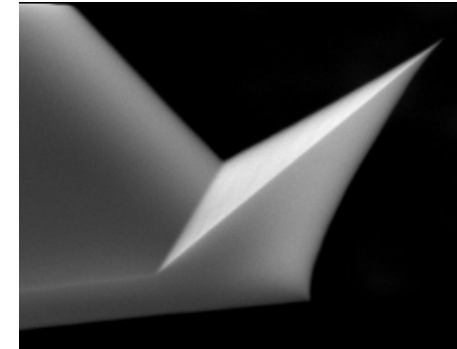
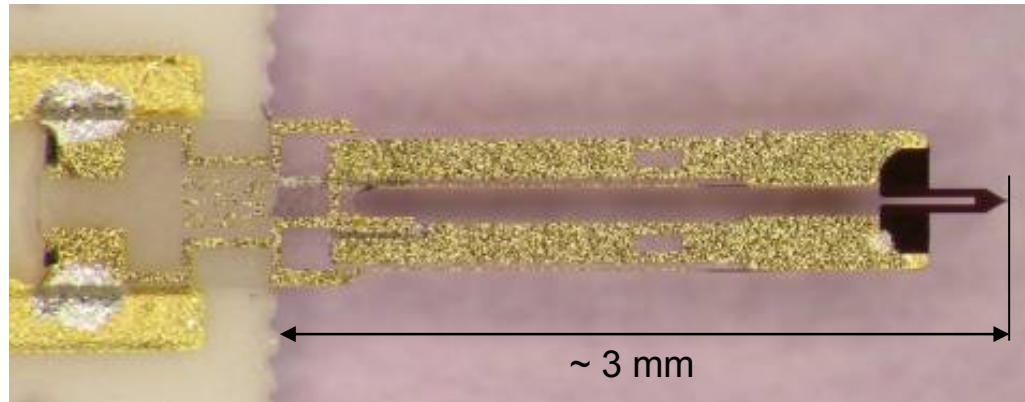

The cantilever is electrically connected to one of the electrodes of the TF.

## Specifications (typical values)

Cantilever	length: 310 $\mu\text{m}$ , thickness: 3.7 $\mu\text{m}$ , width: 30 $\mu\text{m}$ each material: $n^+$ silicon (0.01 - 0.025 $\text{Ohm}\cdot\text{cm}$ )
Tip	AdvancedTEC™-like tip radius <15 nm, tip height 28 $\mu\text{m}$
Force constant	5 N/m (Si cantilever)
Resonance frequency	~ 50 kHz
Ceramic plate	approximately 6.5 mm x 5.1 mm x 0.4 mm

All values are subject to change without notice.

# Ceramic plate

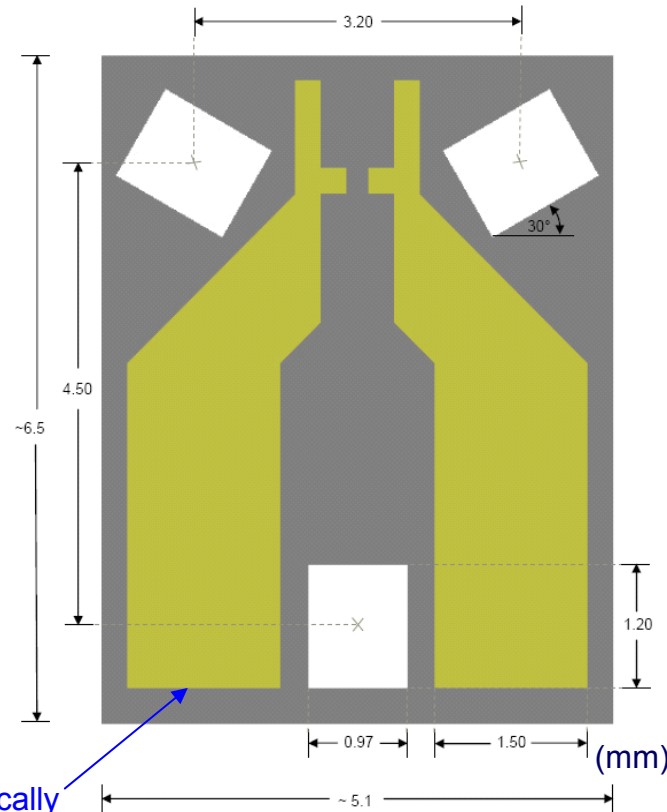

This side is electrically connected to the cantilever.

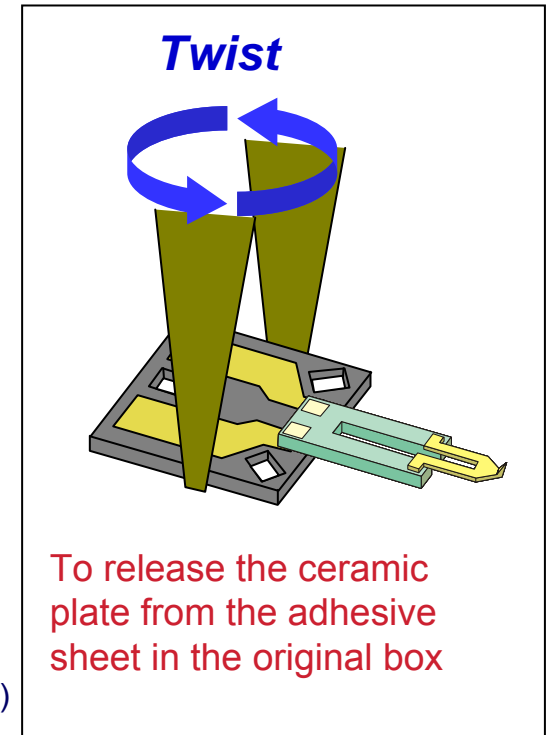

NANOSENSORS™ original ceramic plate for Akiyama-Probe with two gold contacts and three through holes. All through holes have the same size and can be used for centering the plate on a counterpart that has three spheres. The thickness is approximately 0.4 mm.

# Probe mount

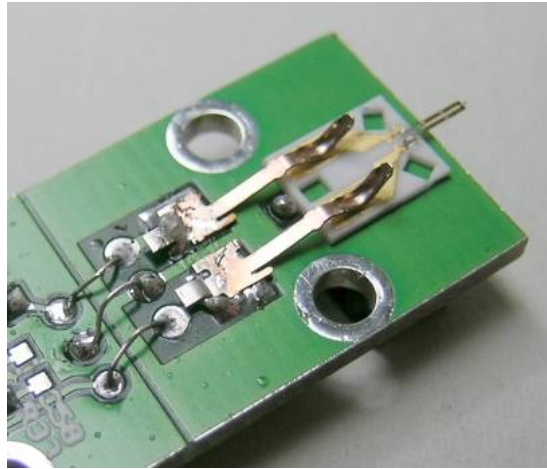

E.g., CONNECTOR, SMARTCARD, 8WAY  
CCM03-3003 LFT — ITT CANNON —

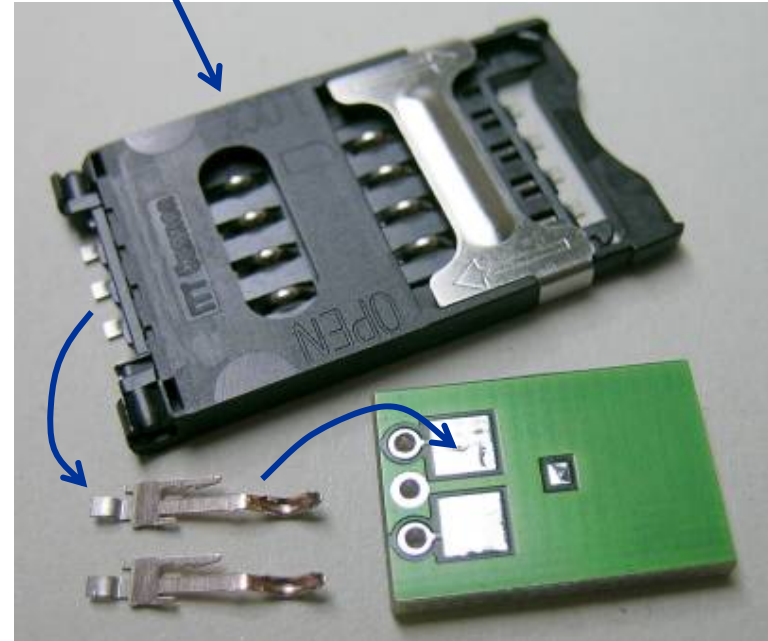

Spring-pins from a memory card connector, which can be easily pulled out, are used. The metal pieces are soldered on a patterned PCB after cutting off excessive parts. As a stopper, a small solder bump is created. It is recommended to have a large ground plane to improve stability of the oscillation.

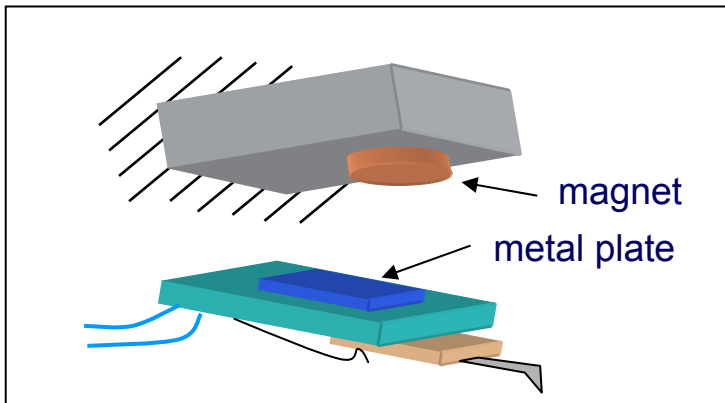

# Amplifier circuit (1)

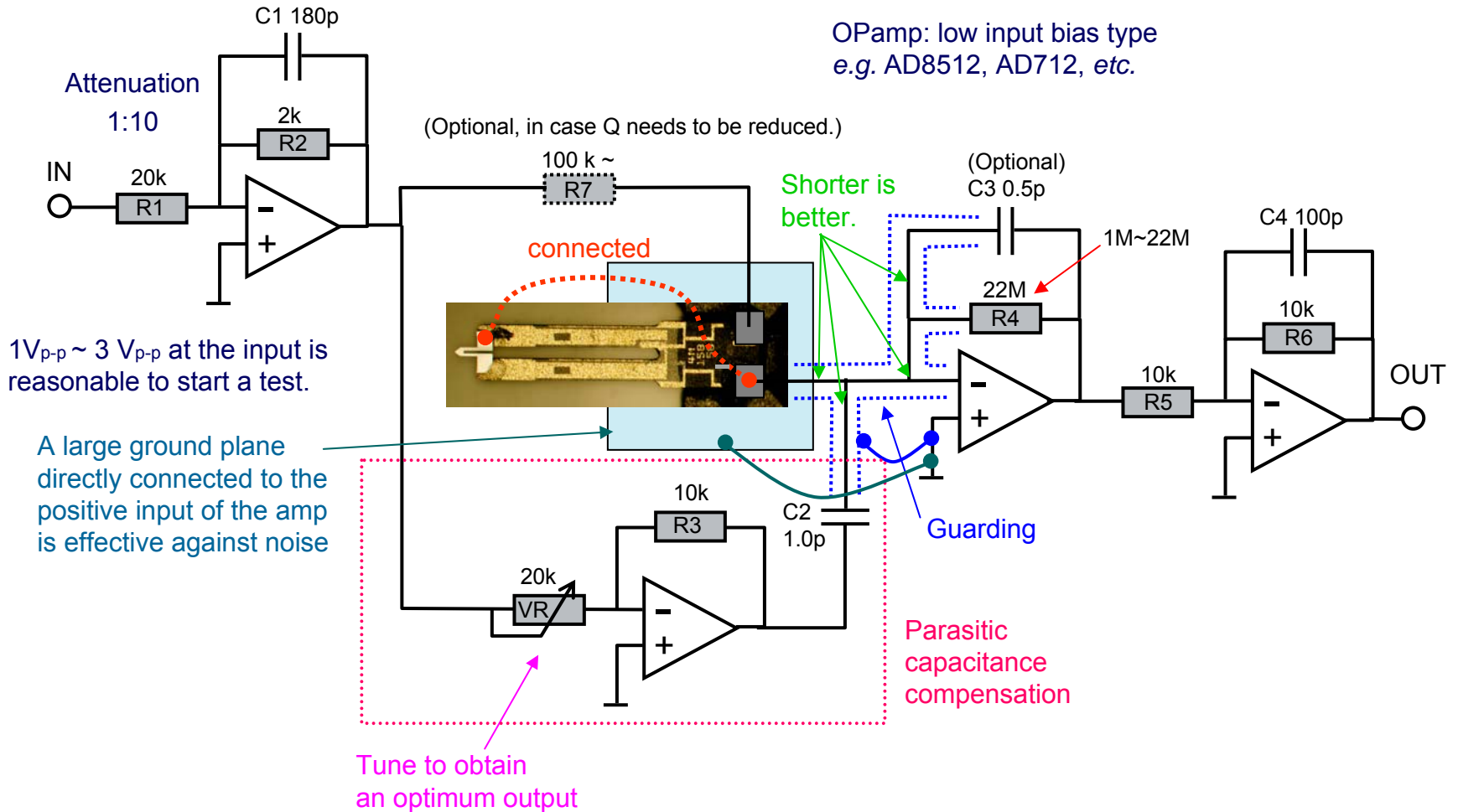

All resistors and capacitors may have to be trimmed accordingly.

## Amplifier circuit (2)

0.1V<sub>p-p</sub> ~ 0.3 V<sub>p-p</sub> at the input is reasonable to start a test.

OPamp: low input bias type  
e.g. AD8512, AD712, etc.

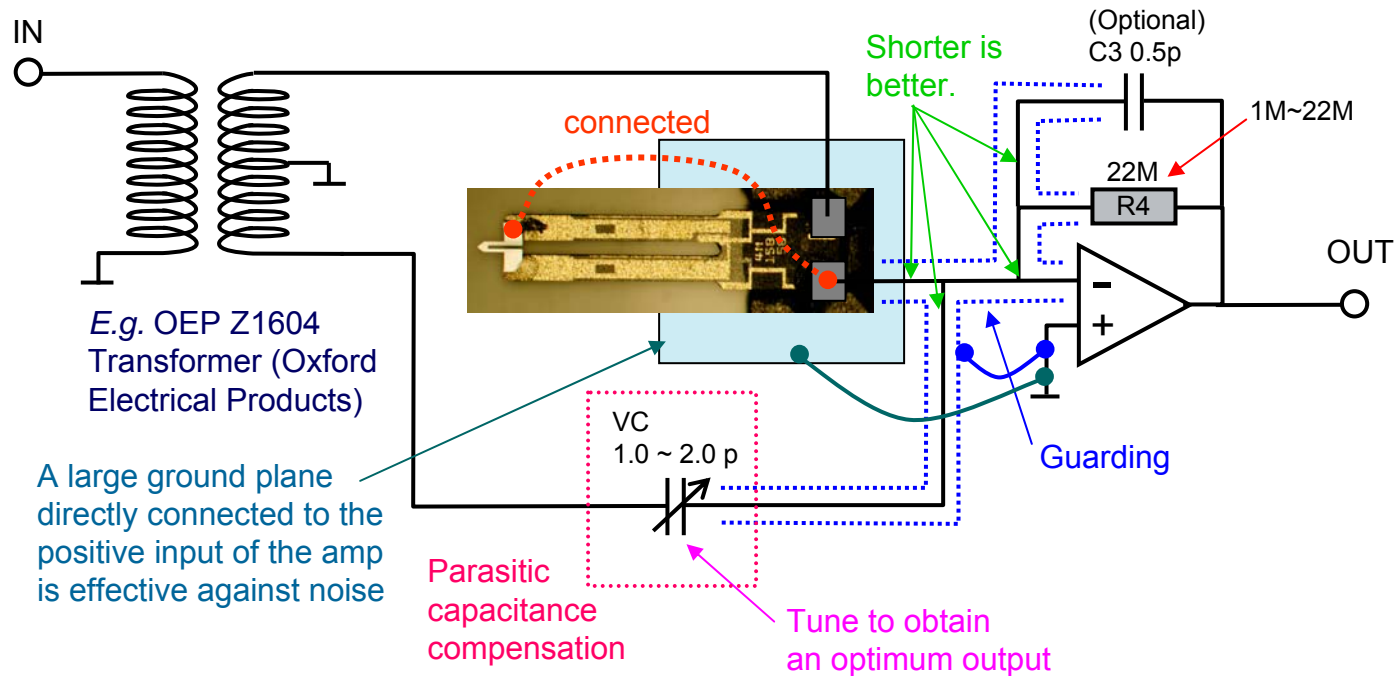

All resistors and capacitors may have to be trimmed accordingly.

## Adjustment of amplifier board

Connect the preamp to e.g. gain-phase analyzer or lock-in amplifier, and find a peak by sweeping the frequency. Adjust the VR (or VC) on the board so that the peak becomes almost symmetric (pink line in the figure). In this condition, the parasitic capacitance around the probe is mostly compensated and only the piezoelectric current is amplified.

If a gain-phase analyzer or a lock-in amplifier are not available, one can use an oscilloscope and a function generator: apply a sin wave to the amplifier board and monitor the output. Adjust the frequency so that a maximum output in terms of amplitude is obtained. Take a note of the frequency and the amplitude. Slightly change the setting of the VR (or VC) to one direction. Tune the frequency again and find a new maximum amplitude. If it is smaller than the previous value, one should repeat the steps. If larger, one should move the VR (or VC) to the other direction. At the optimum setting, the output amplitude is smaller than with any other settings.

Each time when a probe is exchanged, it is advised to readjust the tuning to obtain the best performance.

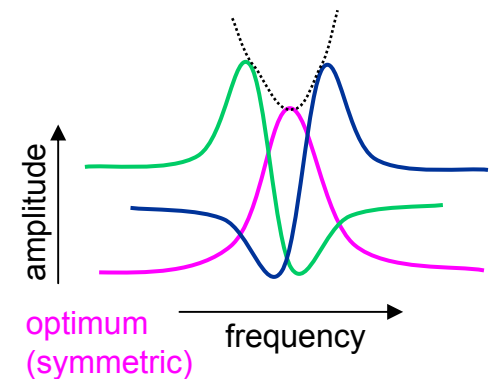
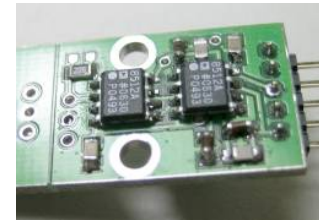
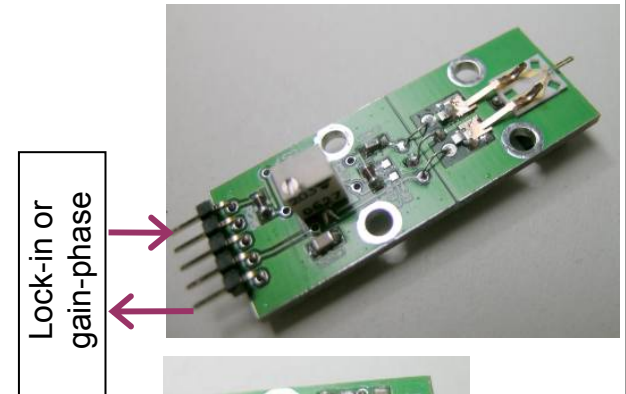

# Simple and low-budget setup

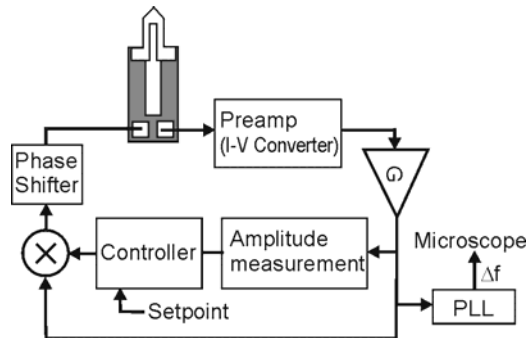

*This example uses a single chip PLL (XR2212) to reduce the total cost. For a higher resolution AFM imaging, it is highly recommended to use a crystal based PLL system.*

## Self-Oscillation + PLL board

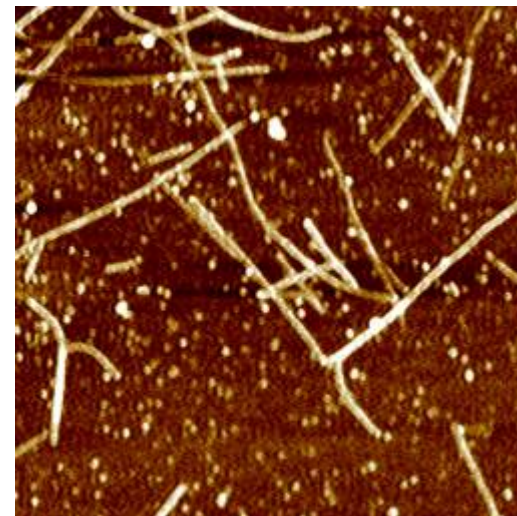

An image of carbon nanotube taken with the simple and low-budget setup, 3  $\mu\text{m}$  x 3  $\mu\text{m}$

## Self-oscillation and simple PLL circuit

All resistors and capacitors may have to be trimmed accordingly.

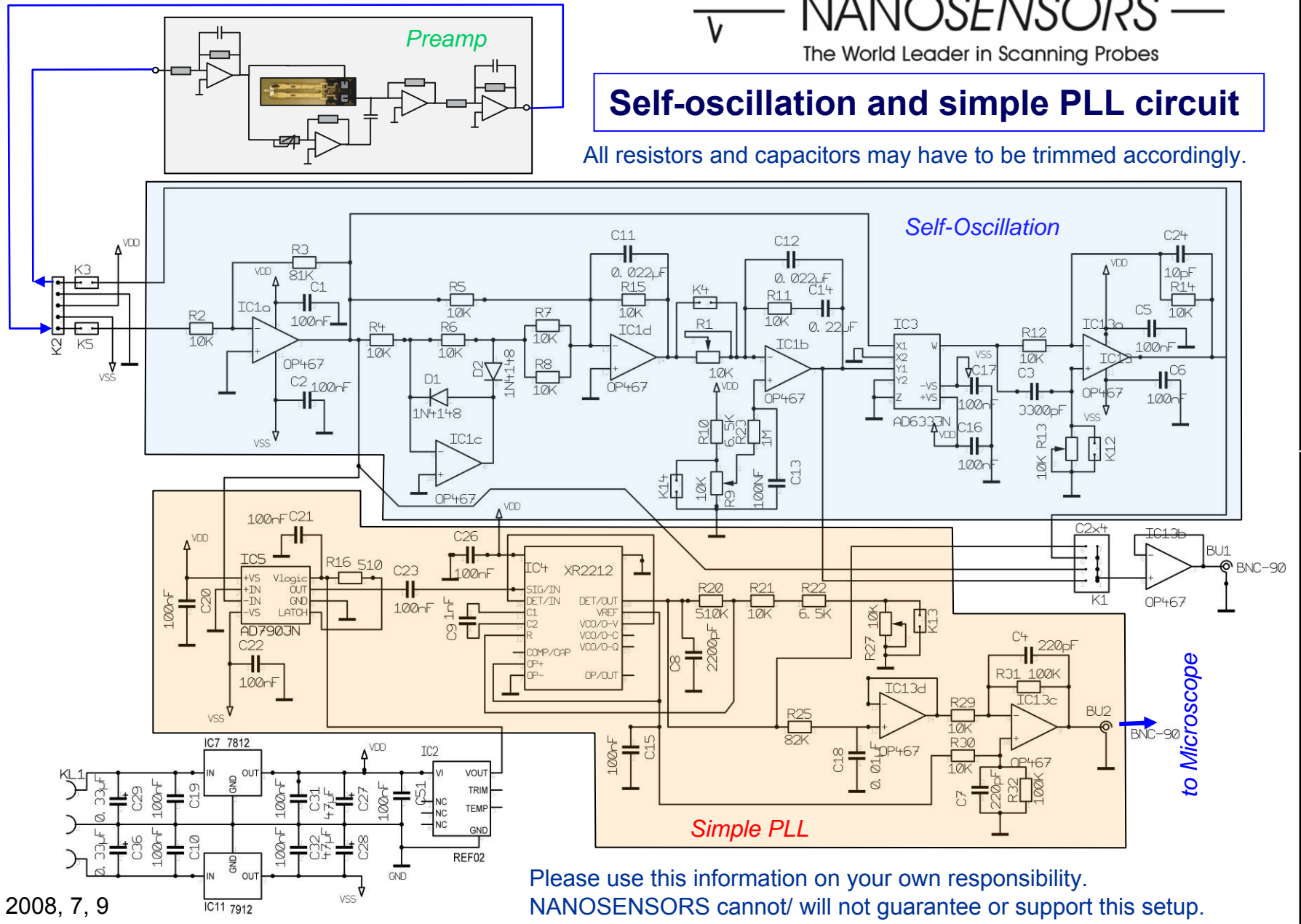

Please use this information on your own responsibility.  
 NANOSSENSORS cannot/ will not guarantee or support this setup.

## Adjustment of the setup

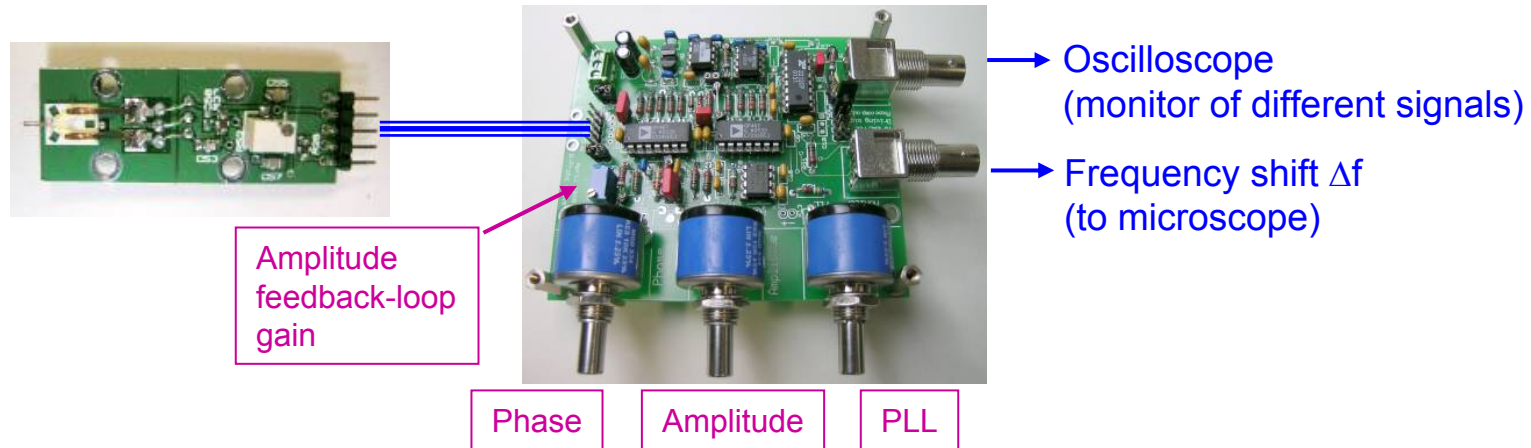

Connect the amplifier board to the main board and the monitor terminal (BU1, selector: K1) to an oscilloscope. Turn on the power. Tune the phase adjustment (R13) until a stable sin wave appears on the signal line going to the amplifier board. Fine-tune the volume so that the sin wave has a minimum amplitude. If no stable signal is obtained, change values of the “amplitude feedback-loop gain” (R1) and/or the amplitude adjustment (R9) and try again. The “amplitude feedback-loop gain” (R1) should be set as high as possible, but low enough to keep the signal stable. The self-oscillation frequency should be approximately the same value as the one obtained in the tuning step of the amplifier board. The tip vibration amplitude can be changed by the amplitude adjustment (R9).

The PLL block is outside of the self-oscillation loop and does not disturb the oscillation of the probe. The PLL adjustment (R27) changes the frequency of the local oscillator, which is compared with that of the self-oscillation. If the two signals are nearly the same frequency, the final output of the PLL block is around zero volts. If the self-oscillation frequency increases, the output also increases.

## Suggestions for operation

- The parasitic capacitance on the probe should be compensated so that only the piezoelectric current is extracted. If not, the electrical peak does not correspond to the real mechanical movement of the tuning fork. Please refer to the electrical setup page.
- Direct electrical driving of the probe is highly recommended. Shaking Akiyama-Probe by external piezo does not yield the oscillation correctly.
- The amplitude of the electrical signal of the tuning fork should be maintained at a constant value with a feedback loop to obtain a higher spatial sensitivity (This does not mean that the mechanical vibration of the tip is kept constant).
- The  $\Delta f$  range is approximately 30 Hz ~ 400 Hz. This range is not guaranteed and subjected to change without any notifications.  **$\Delta f$  varies depending on temperature and humidity.** A reasonable frequency offset (setpoint) for “approach” is 5 Hz ~ 30 Hz, depending on  $\Delta f$ .
- For measurements in ambient conditions, it is better to set a relatively large tip vibration amplitude. In an extreme case, the tip vibration can be more than 10  $\mu\text{m}$  peak-to-peak. A real tip amplitude can be estimated from a full stroke approach curve.
- Akiyama-Probe is designed for operation in ambient conditions. It may work in other conditions, like vacuum, UHV, or low temperatures, etc.

**THANK YOU FOR  
YOUR INTEREST**

**NANOSENSORS™**

**NANOSENSORS™**  
The World Leader in Scanning Probes

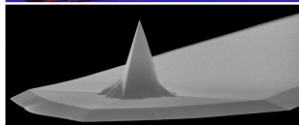
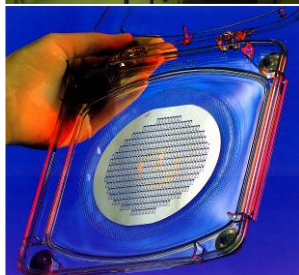

**NANOSENSORS™**

**Rue Jaquet – Droz 1  
Case Postale 216  
CH-2002 Neuchâtel  
Switzerland**

**phone: +41 32 720 5085**

**fax: +41 32 720 5792**

**info@nanosensors.com**

**www.nanosensors.com**

